



Assembly Instructions

Thank you for purchasing a Shelti product. All of us at Shelti want you to be completely satisfied with your Coin Pool Table, so feel free to contact us for help with the assembly of your product, Shelti parts, or other information you may require.

Tools Required:

5/16" Wrench or Socket
Level

<u>Description</u>	<u>Part Number</u>	<u>Quantity</u>
Shelti Pool Table Leg Box	LBA-0	1
Pool Table Leg Assembly	PX-LAA-0	4
Pool Table Leg	201-0053-0	4
Square Base T-Nut 1 3/8"x1 3/8"	305-0010-0	4
#8 x 1 1/4" Pan Phil Tap Screw	304-0002-0	4
Leg Leveler - Brushed Aluminum	204-0035-0	4
Leg Bolts - 5/16-18x1 1/2"	301-0020-0	12
Ball Set - With Magnet Cue Ball	213-0001-0	1
Ball Rack Triangle	201-0060-0	1
Pool Table Chalk	210-0047-0	6
Pool Table Warranty Card	210-0063-0	1
8" Coin Pool Table Assembly Instructions	210-0158-0	1

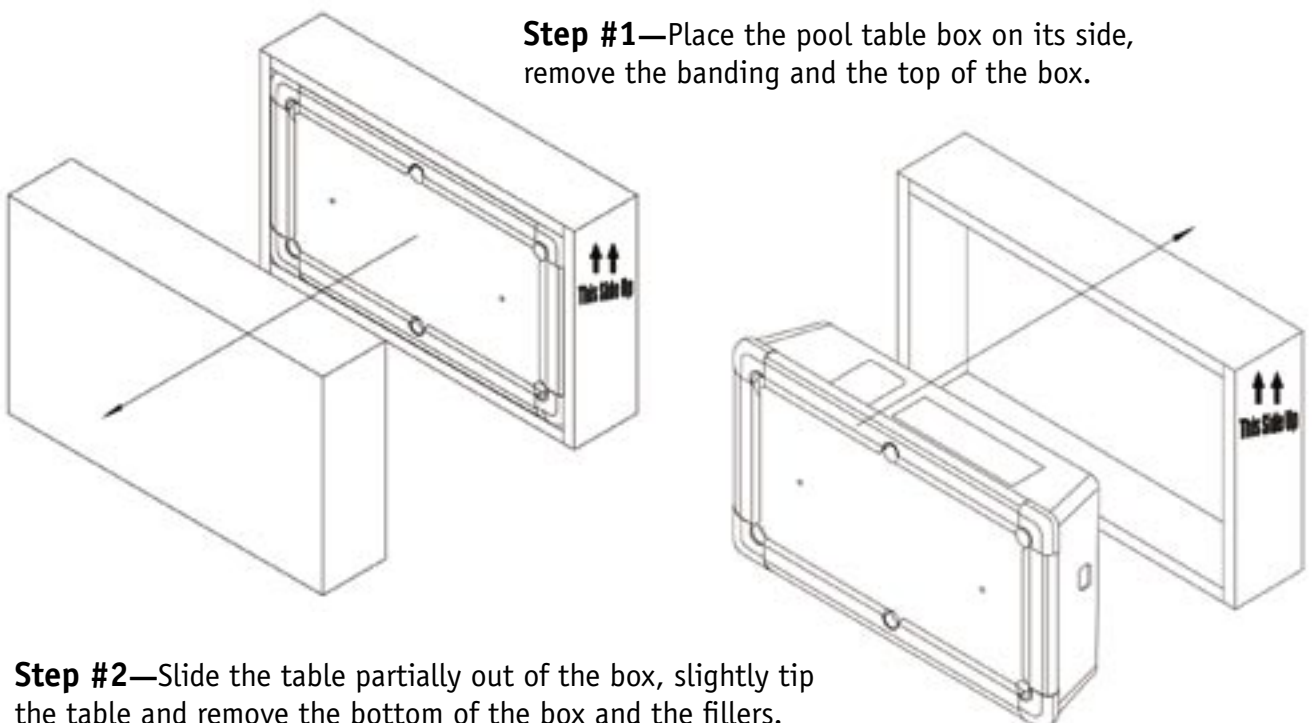

Step #3—Attach the legs to the bottom of the pool table using three 5/16"-18 leg bolts per leg. Make sure that the leg levelers are screwed all of the way into the leg and slowly rotate the table over onto its four legs.

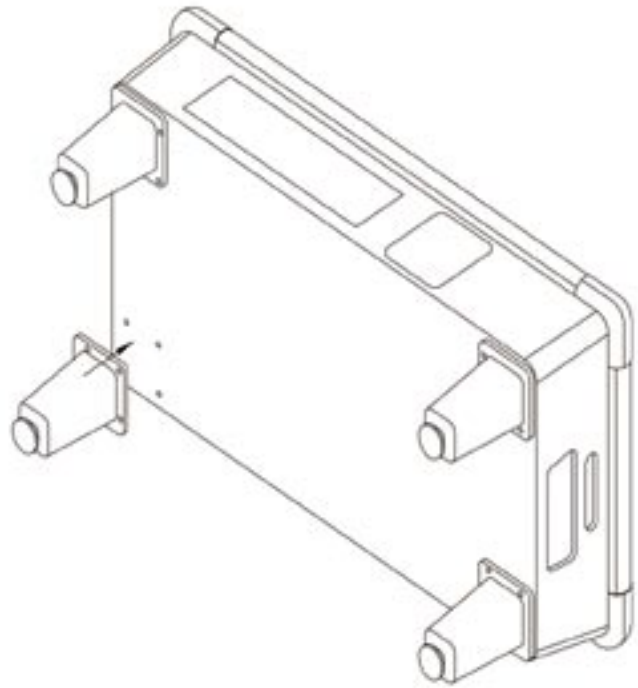

Step #4—Rough level the pool table by placing a level across, lengthwise, and diagonally into the four corners and raise or lower the appropriate leg leveler. Final level the pool table by dropping a ball onto the nose of the cushion rail and watch the drift of the ball as it comes to a stop. Raise or lower the appropriate leg leveler until the ball rolls true.

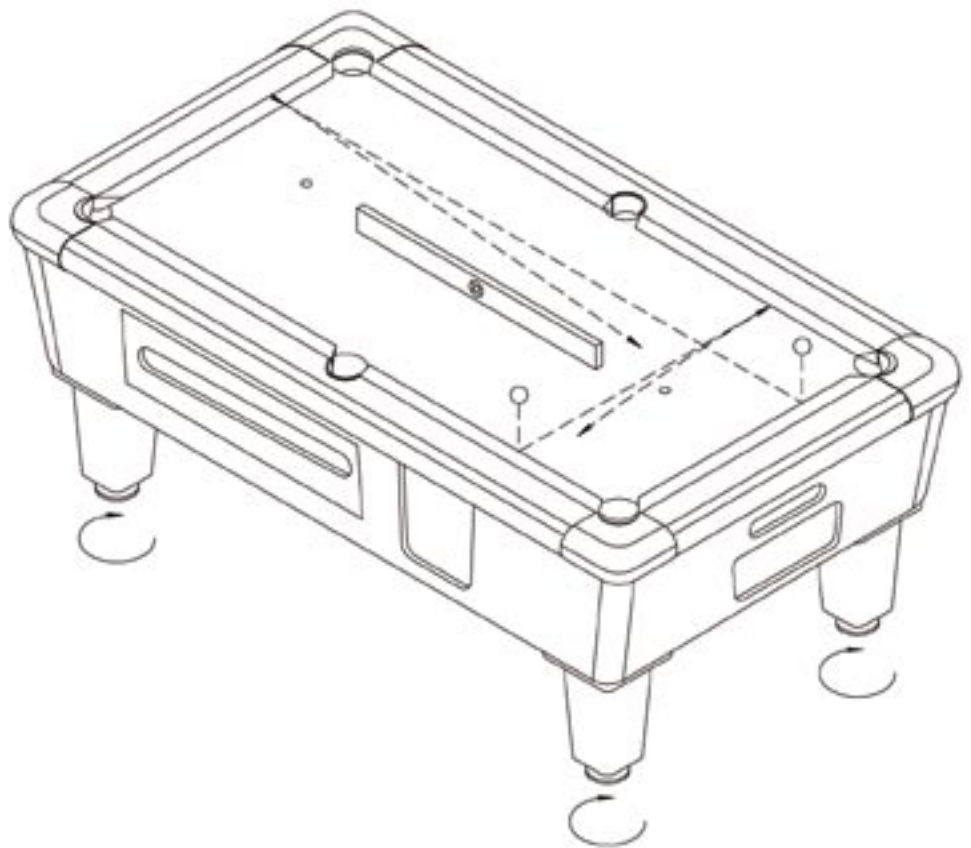

Step #5—Complete the warranty card and return the self-mailing Registration Form to Shelti in the event of upgrades and/or product recalls.

Maintenance Adjustments

Top Rail Molding Removal / Installation:

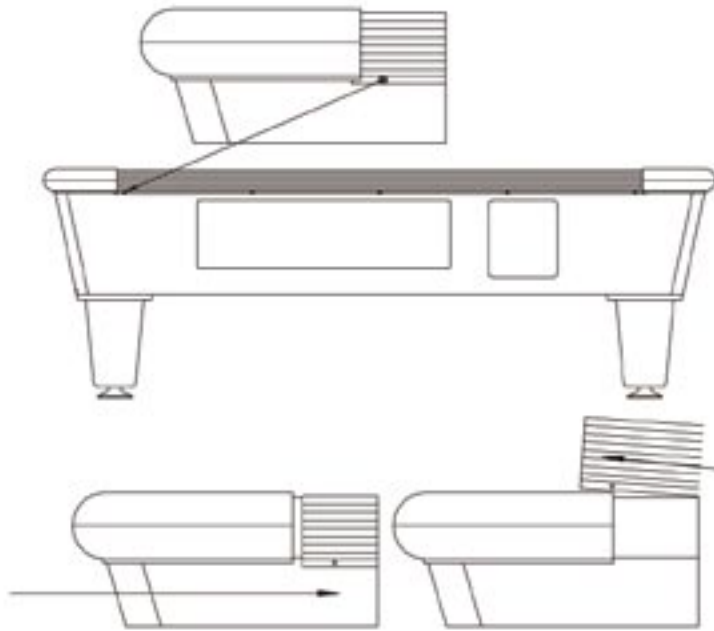

Step #1—Remove the top rail molding screws.

Step #2—Slide the molding all of the way in one direction.

Step #3—Lift the molding on one end and slide it in the opposite direction to remove.

Cue Ball Separator Adjustment:

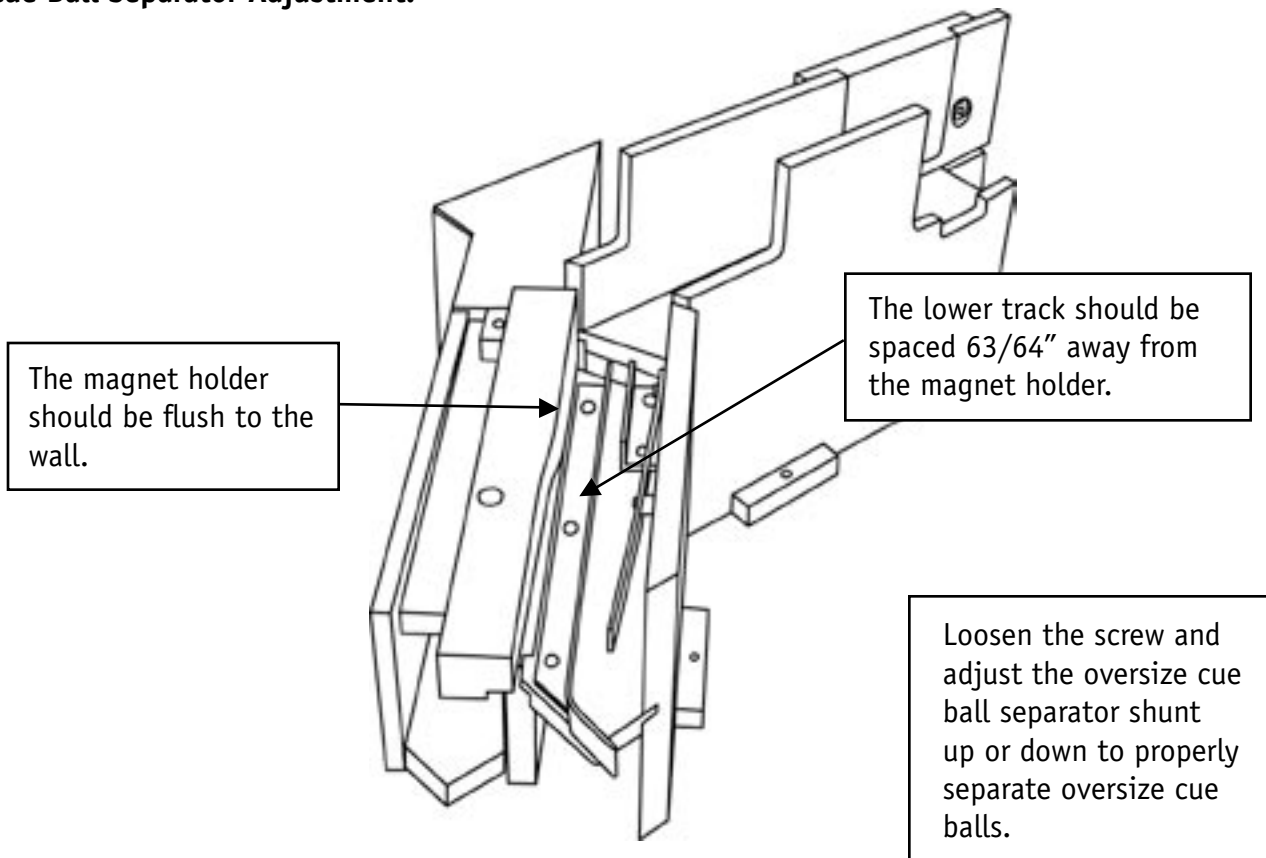

Ball Trap Removal & Upper Ball Wedge Replacement:

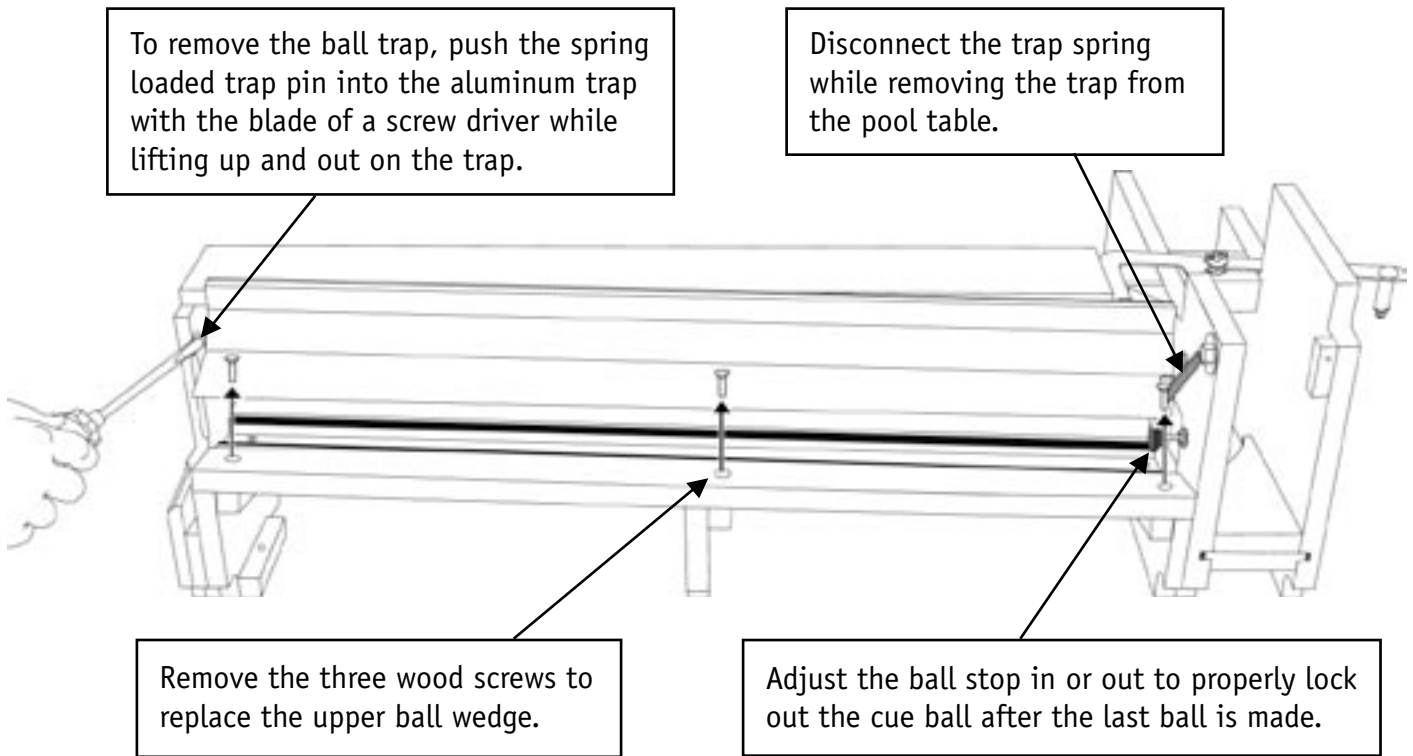

Die Cast Corner Removal / Installation:

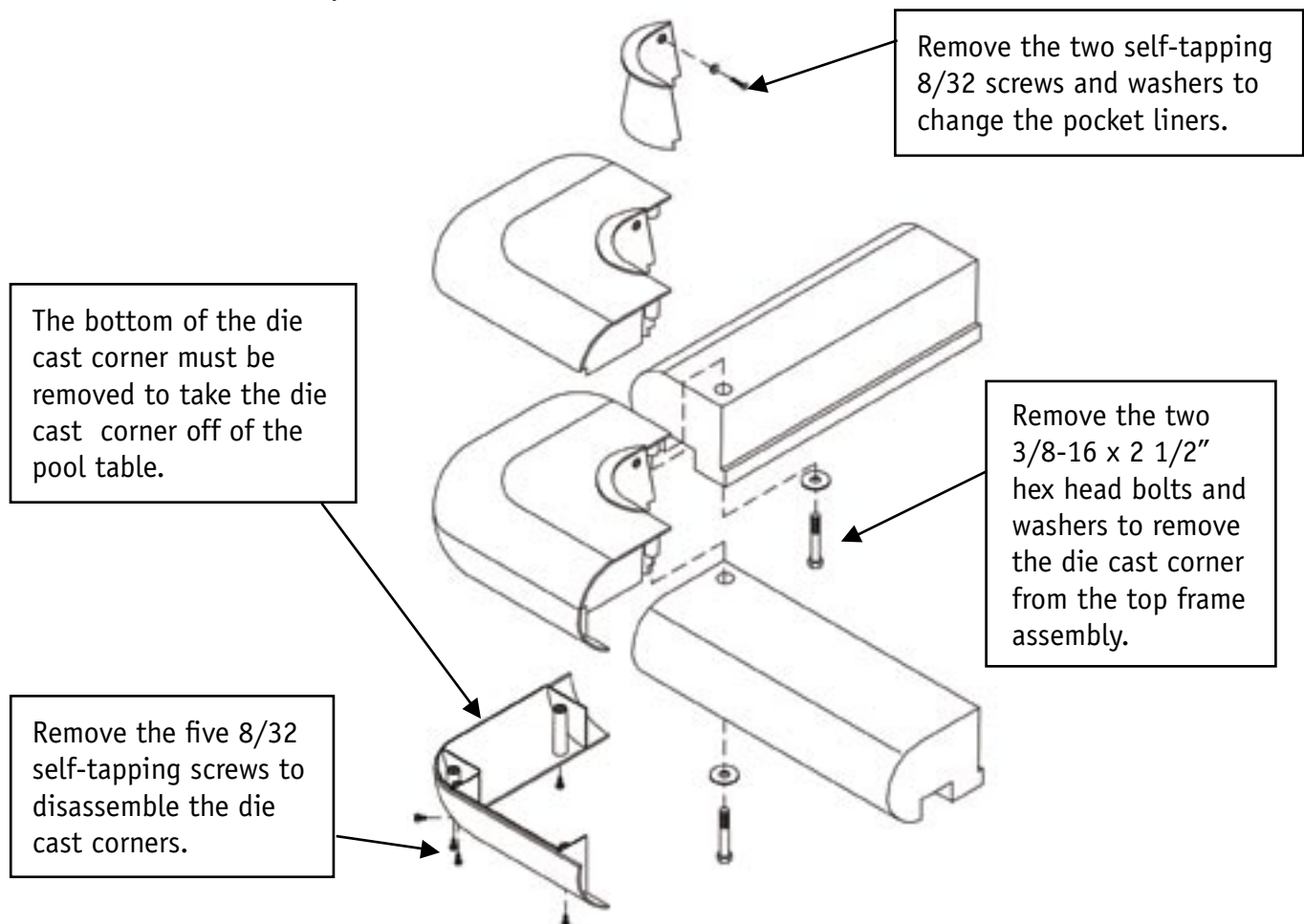

Ball Trap Cam Removal / Adjustments:

The balls should pass freely beside the anti-cheat pin when the ball trap cam is at rest.

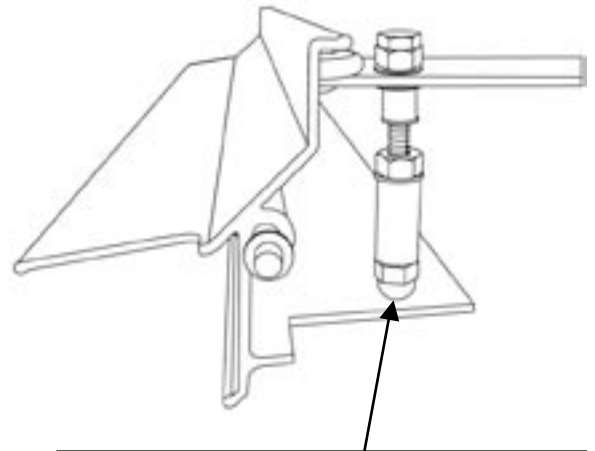
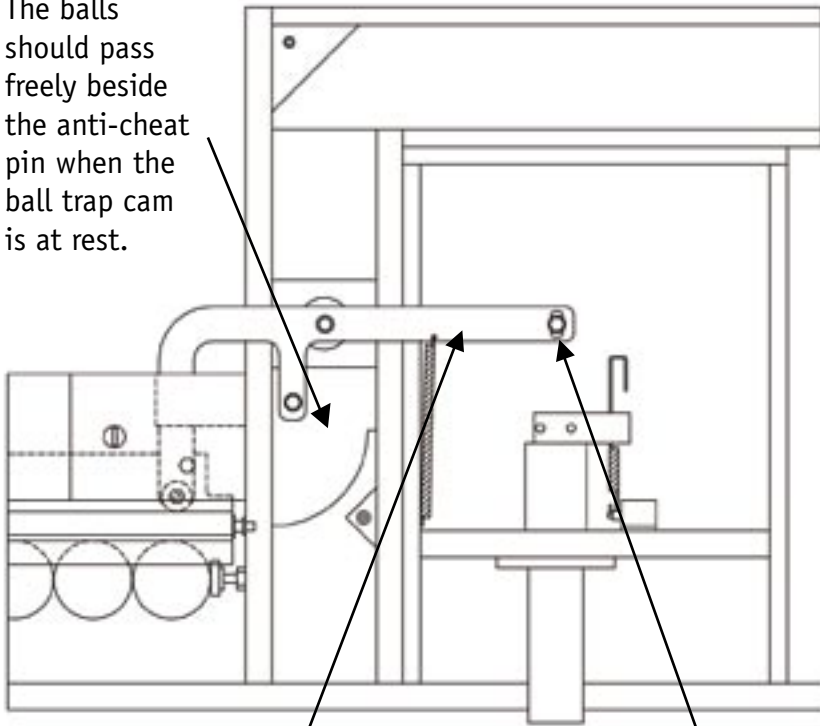

The acorn nut should be adjusted so it is just above the anti-cheat plate in the resting position. There needs to be enough space so that the F-bracket can move smoothly when the coin-mech is actuated.

This view shows the ball trap cam at rest with the balls trapped in the ball trap.

The normal adjustment of the 5/16-18 carriage bolt with brass bushing is in the center of the groove. Adjust this bolt forward to increase the sensitivity of the ball trap or back to decrease the sensitivity of the trap.

This view shows the coin chute pushed in rotating the ball trap cam into the back of the aluminum ball trap which dumps the balls.

This view shows the coin chute pushed in rotating the ball trap cam into the back of the aluminum ball trap which dumps the balls.

The counter spring is pulled as the coin chute is pushed in actuating the counter.

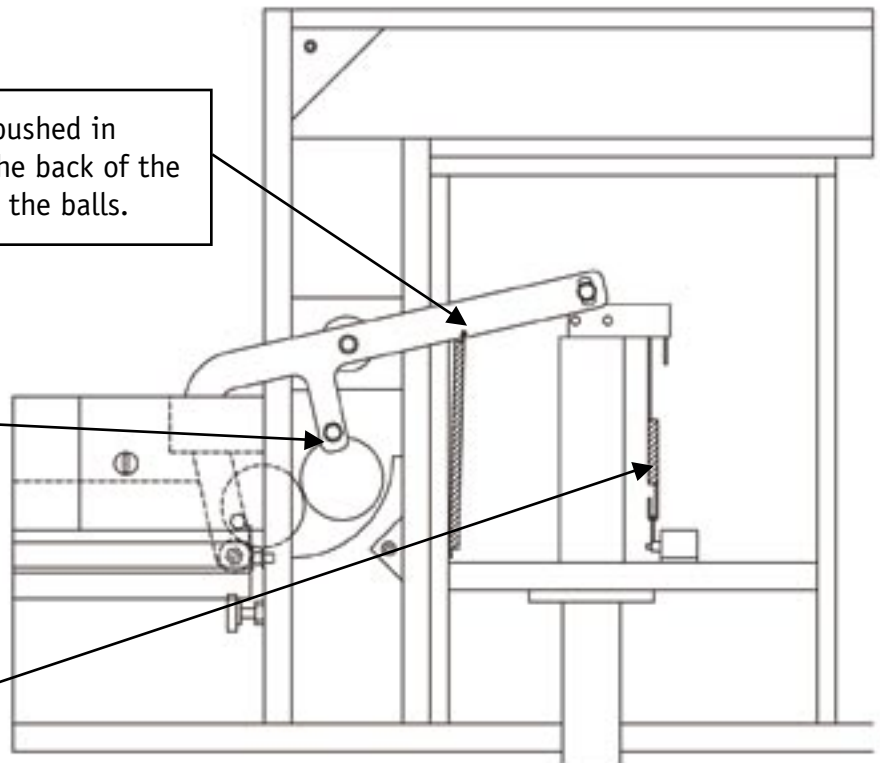

333 Morton Street
Bay City, Michigan 48706
Phone: 989-893-1739
Fax: 989-893-1809
www.shelti.com
info@shelti.com